



enhanced performance

filter management

increased efficiency



# Advanced Particulate Monitoring Solutions for Dryers

US-EPA  
MACT



Particulate  
0-30mg/m<sup>3</sup>  
0-150mg/m<sup>3</sup>



BlmSchV 17 0-15mg/m<sup>3</sup>  
BlmSchV 13 0-150mg/m<sup>3</sup>  
BlmSchV 27 0-80mg/m<sup>3</sup>



Certificate No: 9389

# PCME's solutions for drying

PCME'S involvement in drying applications over the last 15 years has led to the development of a unique range of particulate monitoring systems. Working in conjunction with the industry's key players, PCME provides an unparalleled range of instrumentation to work in the difficult monitoring conditions associated with agglomeration, spray and fluid bed drying and other related processes.

## Meeting the challenges of drying applications

For many years, operators of drying process have sought to find the solution to the reliable measurement of particulate emissions from drying/cooling and agglomeration systems. Whether they be in the food, chemical or pharmaceutical industries they have all found a common problem associated with their process which is simply the moist conditions found in emission stacks together with the sticky nature of particles passing through systems making the reliable monitoring of particulate emissions extremely difficult.

The type of filter plant used after Dryers are usually Cyclone or Multi-Cyclone systems, this is because the particulate and gasses driven off these processes are usually extremely damp (relative humidity tends to be well in excess of 30%) making it impracticable to use fabric filters although some specialised processes may use them.

measurement errors. The sticky particulate in the emissions stack tends to adhere to the instrument's optics again causing measurement errors and huge maintenance issues.

Triboelectric systems are also prone to problems caused by the stack conditions. These include desensitisation of the probe caused by product build-up and sensor short-circuiting caused by the high process moisture content. Both these issues are extremely difficult to identify on such instruments, putting the reliability of results in question. PCME has overcome monitoring problems associated with Spray Drying Process by developing a **patented fully insulated sensor** incorporating unique, **Electrodynamic®** non-contact, charge coupled, monitoring technology.



Both PCME's Electrodynamic® technology and fully insulated sensors are subject to Patents Worldwide



Fully Insulated Sensors are unaffected by product build-up on the sensing element

The monitoring of these processes has always been very difficult. Optical systems utilising Opacity, Scatter and Dynamic Opacity techniques fail due to interference of the light beam by the water vapour driven off in the process causing the transmitted light to reflect and refract leading to

PCME's Insulated Sensor provides an **Industry Proven Solution** for drying applications and has been successfully utilised by leading manufacturers of **Foodstuffs, Pharmaceuticals and Chemicals** in **thousands of applications worldwide.**

Spray Drying//

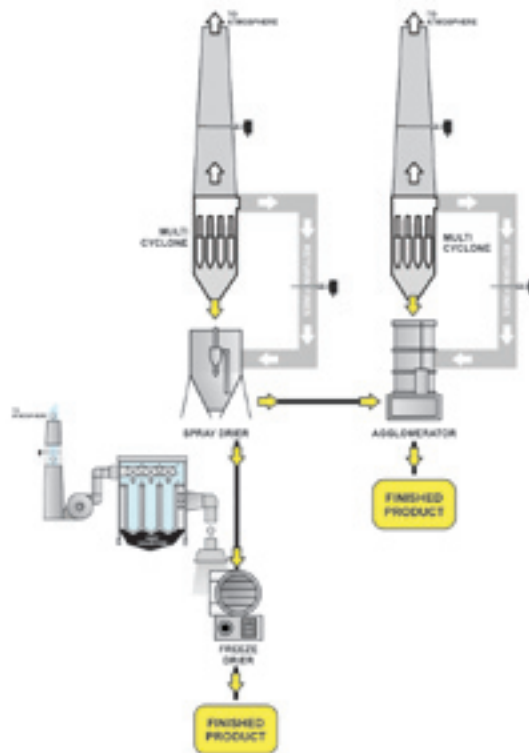

Typical applications within the drying industry

# and agglomeration process

PCME's fully insulated instruments working in the moist and sticky conditions found in drying stacks not only protect our environment by aiding legislative compliance but also decrease operator costs by helping to reduce product losses, filter maintenance costs and production downtime.

Many units have been supplied into industries such as Coffee, Milk Powder and Pharmaceutical manufacture on Drying and Agglomeration processes and in Animal Feed, Pet Food and Sugar production on Cooler/Dryer applications where accurate, accredited systems (TUV/MCERTS) are required to meet legislative requirements (IPPC etc). These fully insulated units have proved themselves not only as a rugged compliance tool requiring low levels of maintenance (typically only a once a year clean prior to calibration/configuration) but also as a preventative maintenance tool for the Dryer Cyclone.

The monitoring of the filter output (both Cyclone and Baghouse) has a number of benefits for the user. Monitoring of the baseline emission trend can indicate when a cyclone is starting to choke and allow the instigation of maintenance to reduce the likelihood of large emission events. Electrodynamic systems used in the milk powder industry have allowed operators to optimise Cyclone performance to such an extent to be able to reduce emissions by over 60%, giving rapid payback time of the instrument and providing a continued reduction in product losses.

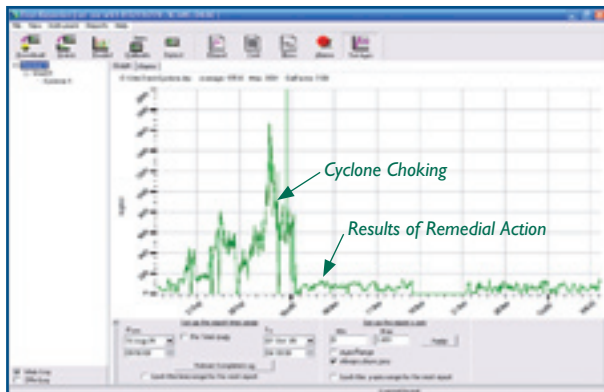

Cyclone Performance Monitoring

In applications utilising bag houses, the monitor may be used in conjunction with a predictive software package to identify potential filter problems before large scale emissions occur saving lost product and maintenance costs and potentially eliminating neighbour nuisance and associated clean-up costs.



Electrodynamic monitoring of Detergent Manufacturing Plant

Dryers tend to be very consistent processes and systems can normally be calibrated to give good and reliable quantitative results, difficulties can arise when a number of differing products (detergent powders for instance) are made in the same dryer. For such applications, instruments are available with the ability to program in multiple calibration factors for differing products, thereby ensuring accurate measurement.



Non-intrusive Flowmaster on 50mm dia Return Fines line

Electrodynamic technology has been incorporated into a range of **non-intrusive Flow Trending** sensors (Flowmaster). These units have been utilised on return fines line to assess the transferred flow of suspended (lean phase) dust.

These units offer real-time information allowing plant operators not only to **predict line blockages** but also to **optimise dryer efficiency**.

Flowmaster units are available with various connections, including Dairy Pipe fittings to allow their use in sanitary applications such as Coffee/Milk Powder production and Pharmaceutical manufacturing.



Agglomeration and Spray Dryer Monitoring using Patented Insulated Probe

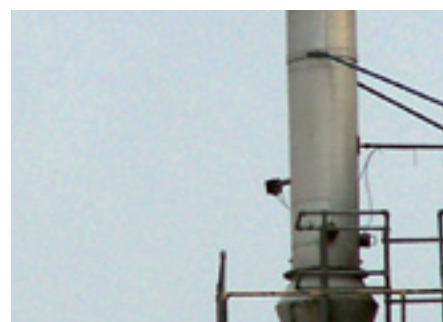

Spray Dryer Multi-Cyclone Optimisation on Coffee Plant

## Cost and Environmental Nuisance Reduction using Filter Failure Prediction

The ability to predict when a bag filter is likely to fail and to be able to identify which row or chamber is at fault has provided users with a proven method not only to reduce the environmental impact and clean-up costs associated with large-scale emission events but also to make significant savings in spares, maintenance times and lost production.

To achieve this a monitor must be able to accurately track the very dynamic dust emissions created during a bag filter cleaning cycle.

As the filter is reverse jet cleaned, any defects in the filter membranes are exposed, resulting in relatively high dust peaks. By monitoring these peaks in real-time using the Predict software package, it is possible to identify potential problems in the filter before they result in breaches of environmental limits.

Predict provides the possibility to observe filter problems remotely and check maintenance work to ensure correct performance of the filter. The use of Predict has proven the ability of a monitor not only to be used for environmental compliance but also to be used as a significant aid to plant maintenance and also enables users to greatly reduce the instances of catastrophic filter failure.

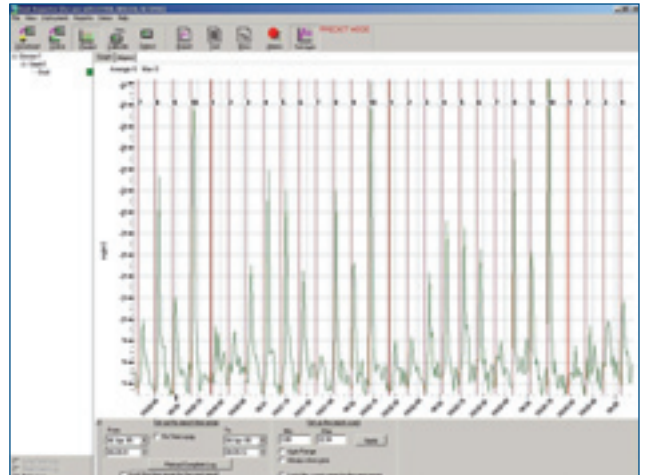

The deterioration of Row 10 is highlighted in real-time before environmental limits are breached

## Network Solutions

Plants employing dryers commonly utilise a number of additional filters (grinding, silo, pneumatic/vacuum transfer units) in remote locations. To monitor these filters PCME provide a wide range of Electrodynamic® instruments ranging from single channel units to multi-channel (up to 32 sensors) systems. These sensors use modbus technology to network to a single control unit. The control unit logs historical data for environmental reporting and process control, displays emission values and allows easy configuration of the system.

The controller may also be connected directly to a LAN to allow remote interrogation of the monitor by a number of different users, environmental, process, maintenance, etc. Both historical and real time data together with alarm status may be displayed simultaneously on different PCs and the Predict software package used to remotely diagnose filter maintenance issues.

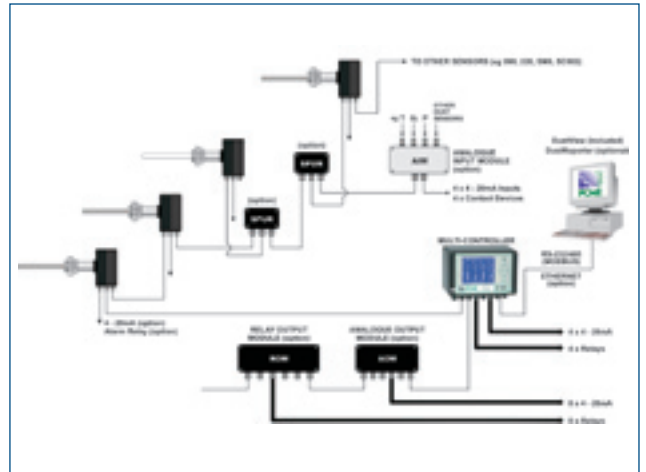

Typical networked system

[www.pcme.co.uk](http://www.pcme.co.uk)

Contact Your National or Area Sales and Service Office:



**PCME Ltd**  
 Clearview Building 60 Edison Road  
 St. Ives Cambs UK PE27 3GH

Tel: Int +44 (0)1480 468200  
 Fax: Int +44 (0)1480 463400  
 E-mail: [sales@pcme.co.uk](mailto:sales@pcme.co.uk)